

EDON fiberglass

<http://www.edon.com>

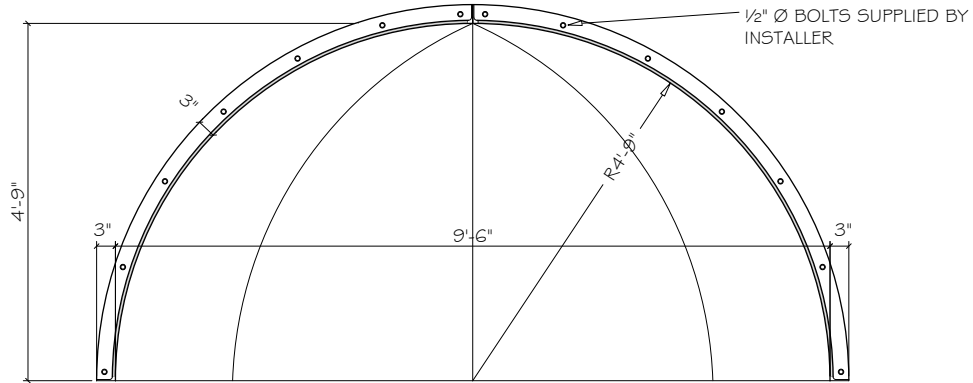

NOTES:

1). ALL BLOCKING, SUPPORT FRAMING, FASTENERS, BONDO, PAINTS AND SEALANTS SUPPLIED BY INSTALLER

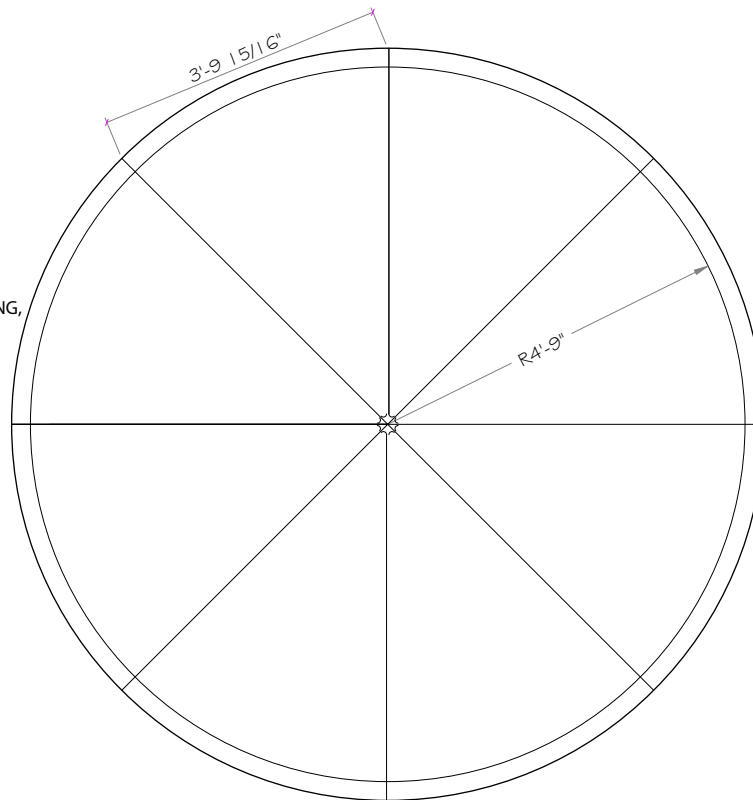

DOMES SHIPPED IN 8 PIE SHAPED SECTIONS

EDI-511 9'-6" DIA. INTERIOR DOME