

EDON fiberglass

~ www.edon.com ~

FOR ANY SILICONE CLEAN-UP, EDON RECOMMENDS USING MINERAL SPIRITS

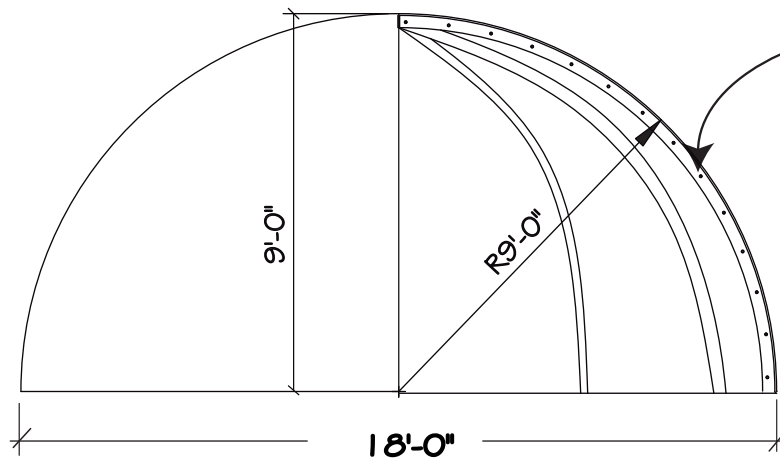

INSTALL STAINLESS STEEL BOLTS IN PRE-DRILLED HOLES. FULLY CAULK BOLT FLANGES PRIOR TO ASSEMBLY.

SECTION/ELEVATION OF EDO-506

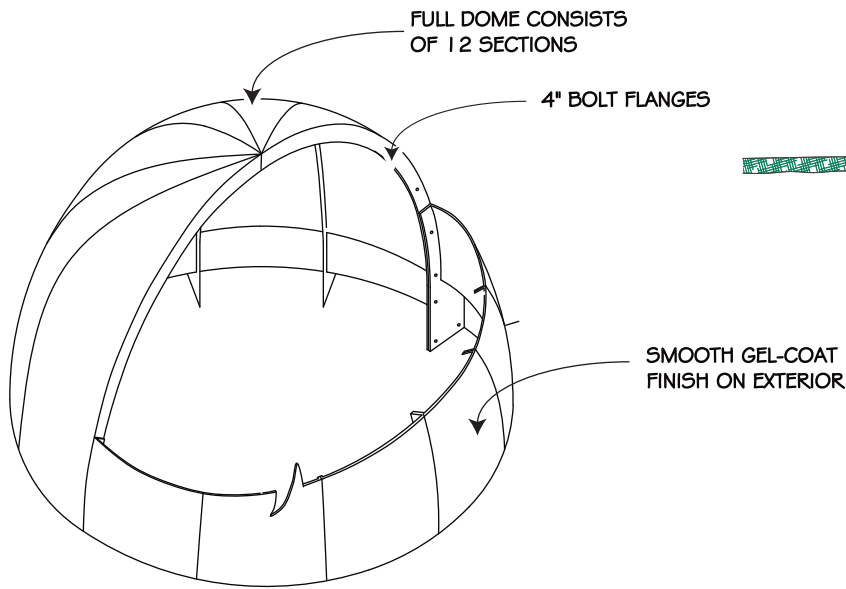

DOMES PLAN DETAIL

BOLT FLANGE DETAIL

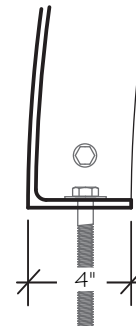
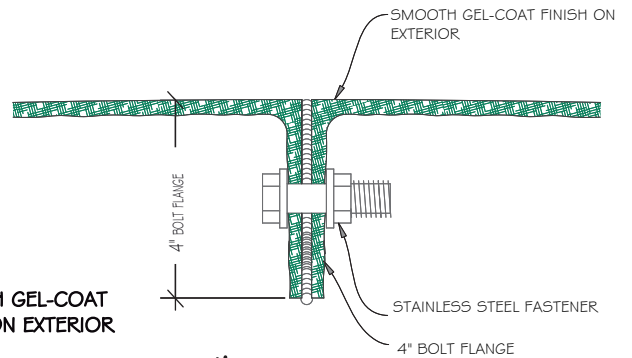

BASE BOLT FLANGE DETAIL

APPROXIMATE DOME WEIGHT = 2,745 LBS.

EDO-506 18'-0" DIA. EXTERIOR DOME (12 SECTIONS)

THIS SHEET IS FOR GRAPHIC REPRESENTATION AND REFERENCE ONLY.

Edon Corp. 1160 Easton Rd., Horsham, PA 19044 ~ Phone: 215/672-8050 ~ Fax: 215/672-9014 ~ Email: edon@edon.com