

EDON fiberglass

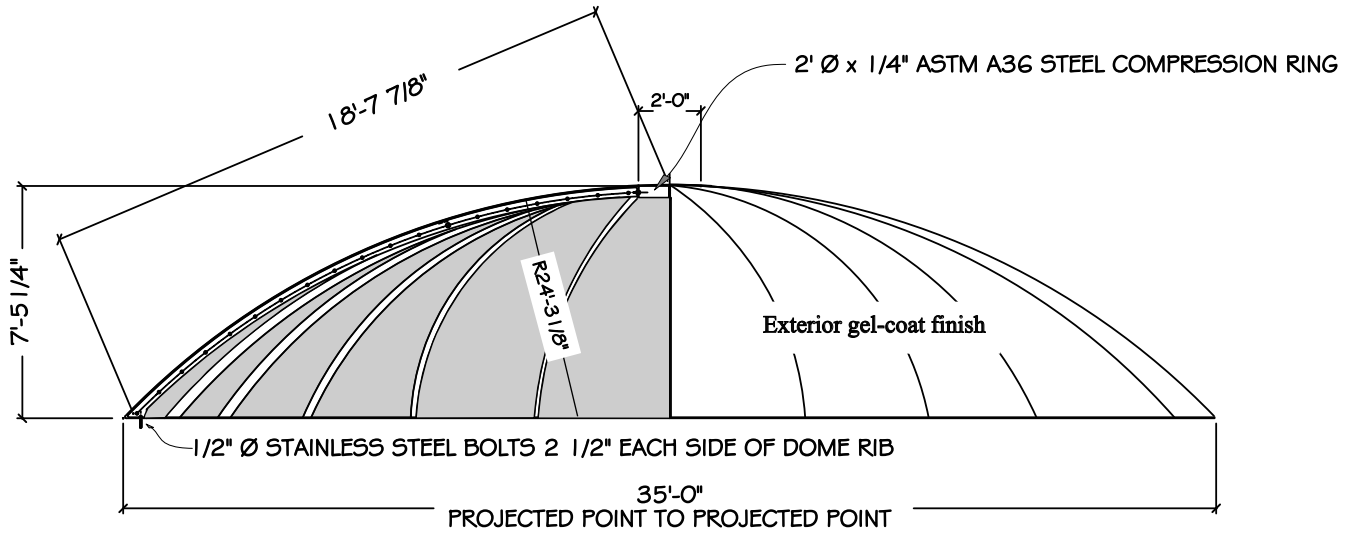

SECTION/ELEVATION OF EDO-527

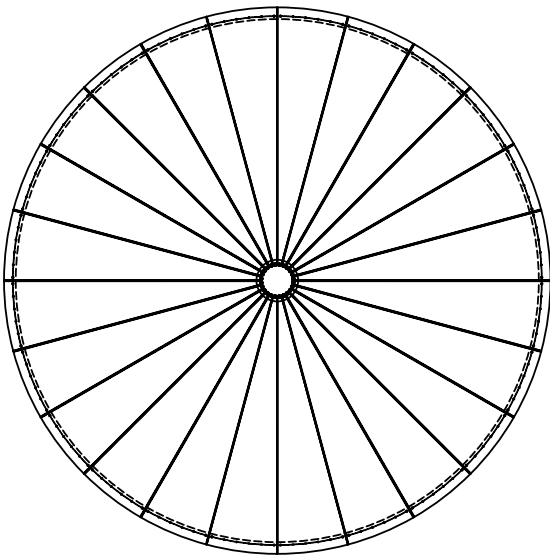

DOME PLAN VIEW

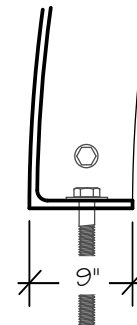
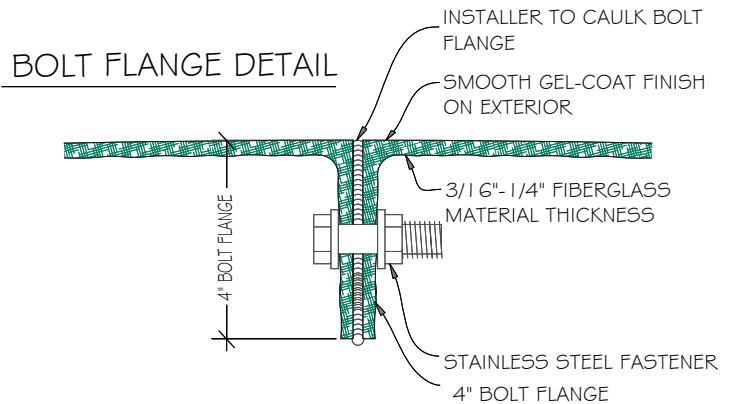

BASE BOLT FLANGE DETAIL

EDO-527 35' EXTERIOR DOME