

EDON fiberglass

<http://www.edon.com>

FOR ANY SILICONE CLEAN-UP, EDON RECOMMENDS USING MINERAL SPIRITS

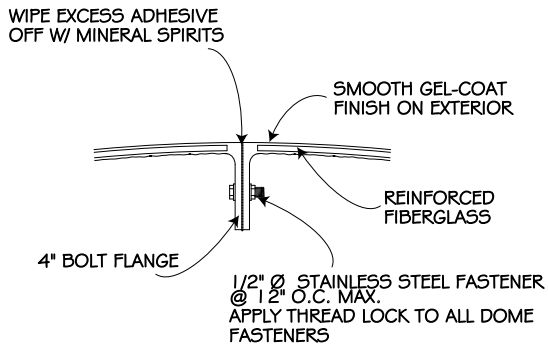

BOLT FLANGE

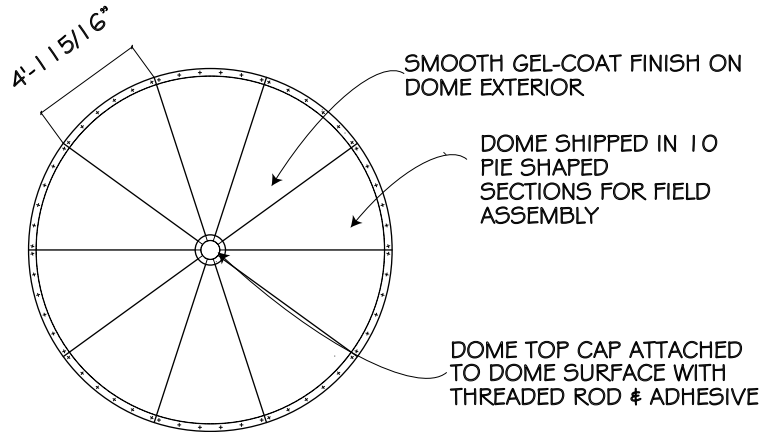

DOME PLAN DETAIL

APPROXIMATE DOME WEIGHT = 1,600 LBS.

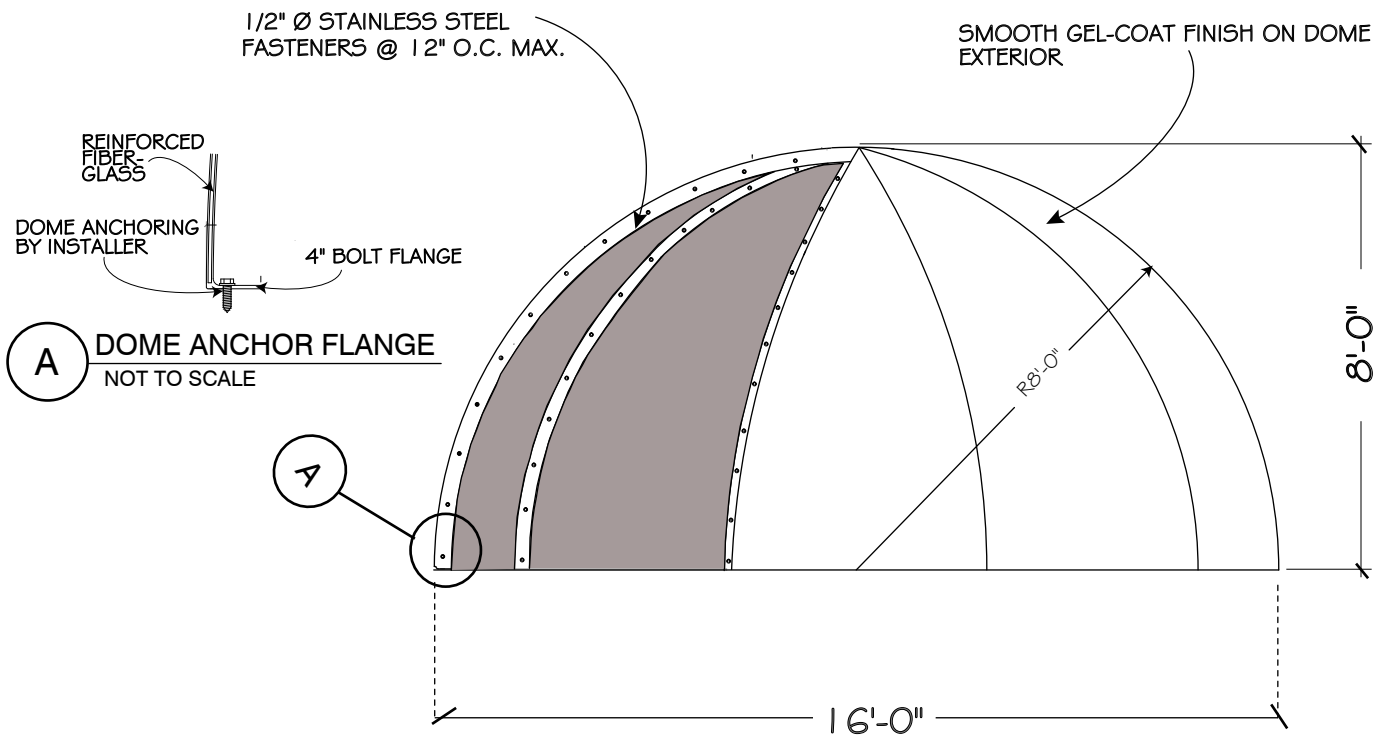

EDO-529 EXTERIOR DOME (10 SECTIONS) 16' DIA. x 8' R

THIS SHEET IS FOR GRAPHIC REPRESENTATION AND REFERENCE ONLY.

Edon Corp. 1160 Easton Rd., Horsham, PA 19044 ~ Phone: 215/672-8050 ~ Fax: 215/672-9014 ~ Email: edon@edon.com