

EDON fiberglass

~ www.edon.com ~

FOR ANY SILICONE CLEAN-UP, EDON RECOMMENDS USING MINERAL SPIRITS

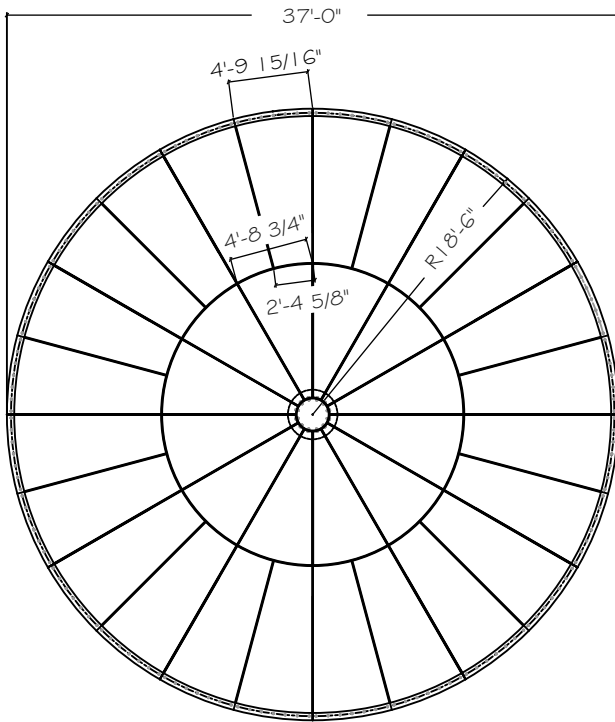

PLAN DETAIL

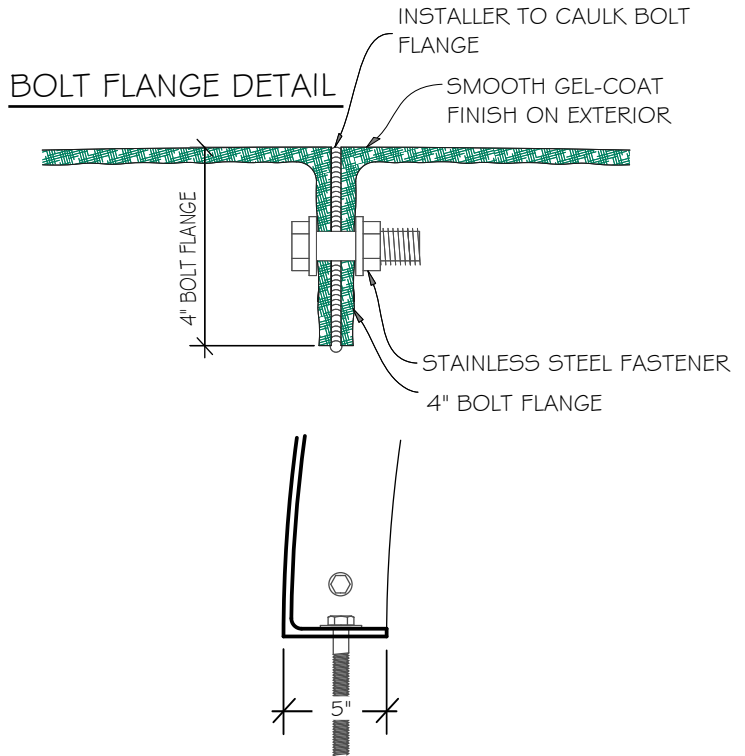

BASE BOLT FLANGE DETAIL

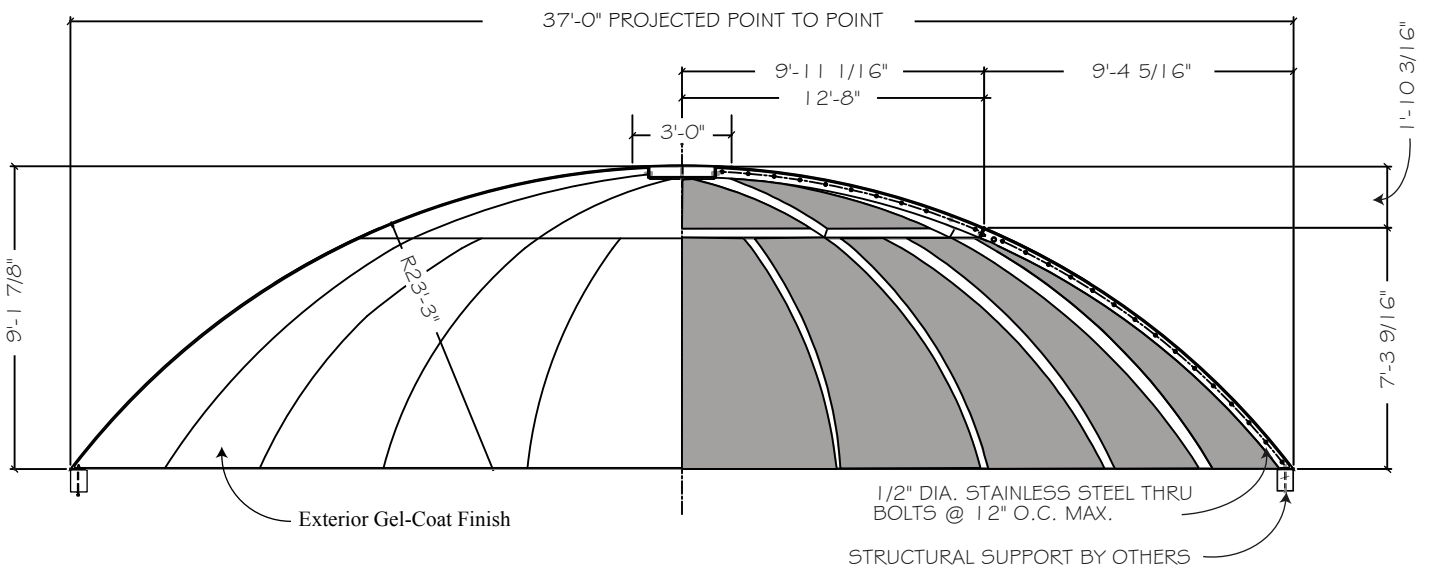

ELEVATION DETAIL

APPROXIMATE DOME WEIGHT = 5,500 LBS.

EDO-532 37' DIAMETER EXTERIOR DOME

THIS SHEET IS FOR GRAPHIC REPRESENTATION AND REFERENCE ONLY.

Edon Corp. 1160 Easton Rd., Horsham, PA 19044 ~ Phone: 215/672-8050 ~ Fax: 215/672-9014 ~ Email: edon@edon.com