

# EDON fiberglass

~ [www.edon.com](http://www.edon.com) ~

FOR ANY SILICONE CLEAN-UP, EDON RECOMMENDS USING MINERAL SPIRITS

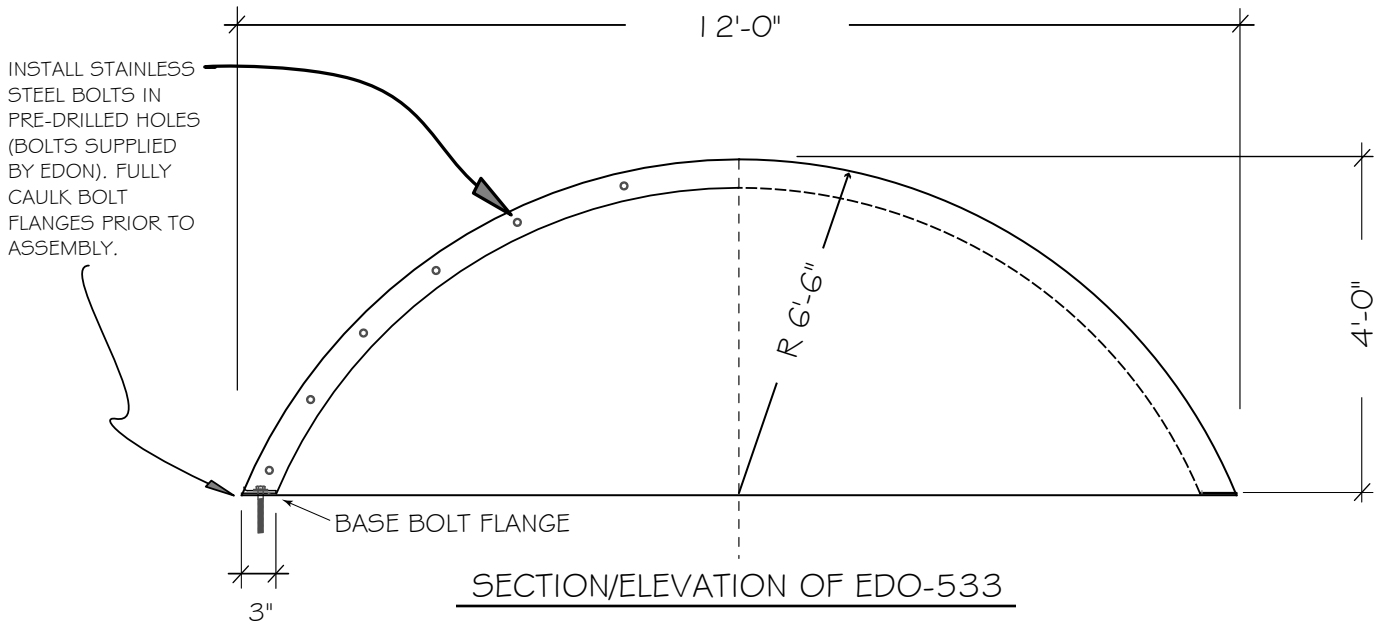

DOMES SHIPPED IN 8 SECTIONS TO BE FIELD ASSEMBLED. ASSEMBLY SHOULD INCLUDE, FULLY CAULKING BOLT FLANGES WITH ADHESIVE/SEALANT

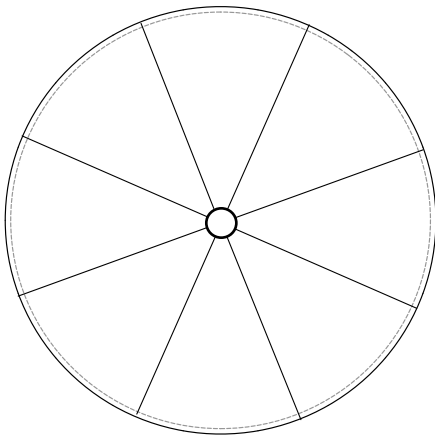

APPROXIMATE DOME WEIGHT = 700 LBS.

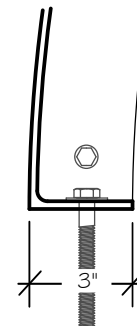
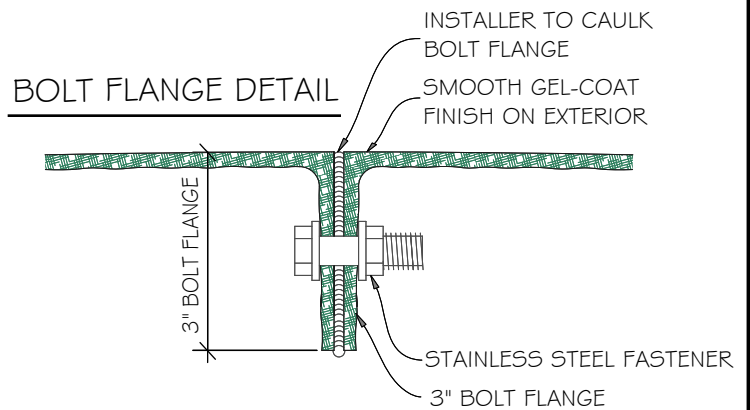

BASE BOLT FLANGE DETAIL

## **EDO-533 EXTERIOR DOME (8 SECTIONS) 12' DIA. LOW RISE**

THIS SHEET IS FOR GRAPHIC REPRESENTATION AND REFERENCE ONLY.

Edon Corp. 1160 Easton Rd., Horsham, PA 19044 ~ Phone: 215/672-8050 ~ Fax: 215/672-9014 ~ Email: [info@edon.com](mailto:info@edon.com)