

# EDON

## FIBERGLASS

### COLUMN

### COVER

### INSTRUCTIONS

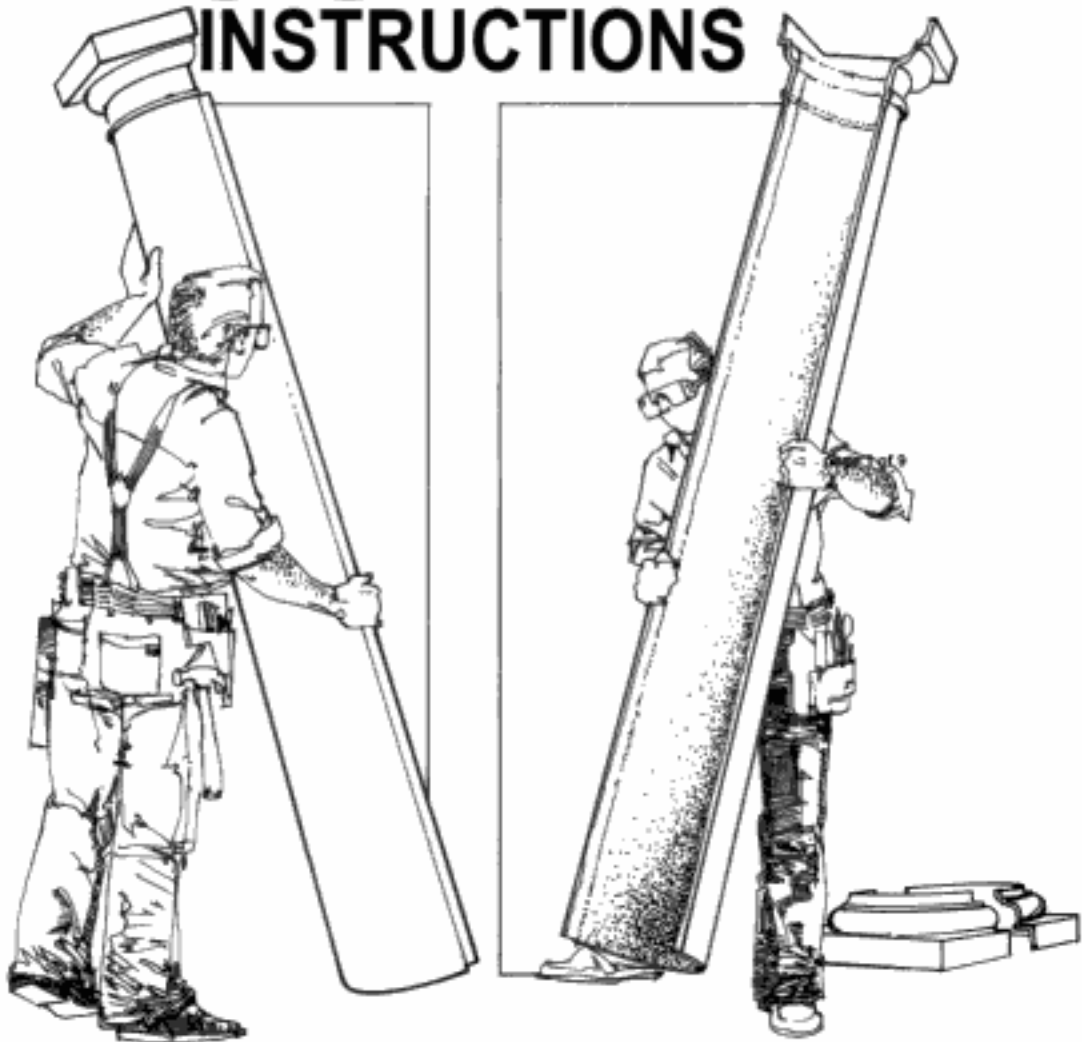

Page 1 of 9



The provided instructions are intended to be used in conjunction with supplied shop drawings and installation video. These instructions and video can also be found on our website at [www.edon.com](http://www.edon.com).

If the shop drawings were waived for your project, EDON still recommends receiving them for installation use.

# EDON fiberglass

## EDON COLUMN COVERS

ARE AVAILABLE IN FOUR TYPES OF JOINTS

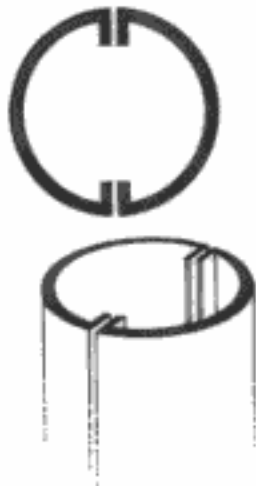

**Butt Joint**  
EXPOSED JOINT  
AVAILABLE IN VARIOUS  
COLORS & TEXTURES



**Lap Joint**  
FILLED & FINISHED JOINT  
FOR SEAMLESS COLUMN  
FIELD PAINT AS DESIRED

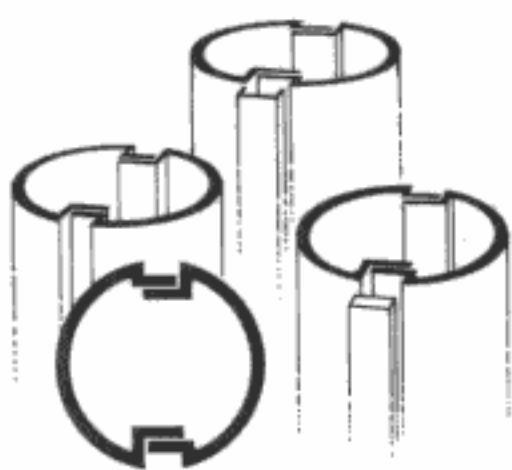

**Reveal**  
THIS JOINT ALLOWS  
FOR REMOVAL OF COLUMN  
COVER FOR ACCESS.  
AVAILABLE IN VARIOUS  
COLORS & TEXTURES

**Reveal  
with  
Insert**  
ACCENT STRIP COVER  
AVAILABLE IN VARIOUS  
COLORS & MATERIALS

### TYPICAL BLOCKING DETAILS

SUPPORT STRUCTURES THAT MAY EXIST

**"I" Beam Support**



**Round Support**



**Square Support**

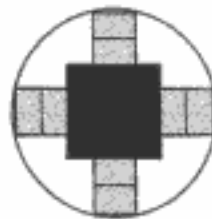
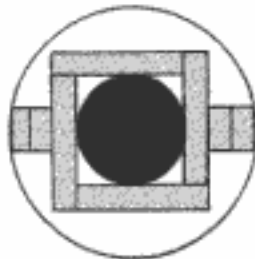
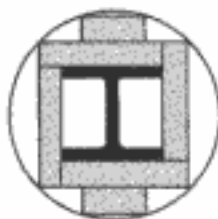

■ = Blocking

■ = Existing Structure

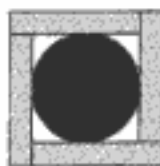

\* SPECIAL SIZES & SHAPES MAY REQUIRE ALTERNATE BLOCKING

# EDON fiberglass

## COLUMN COVER INSTRUCTIONS

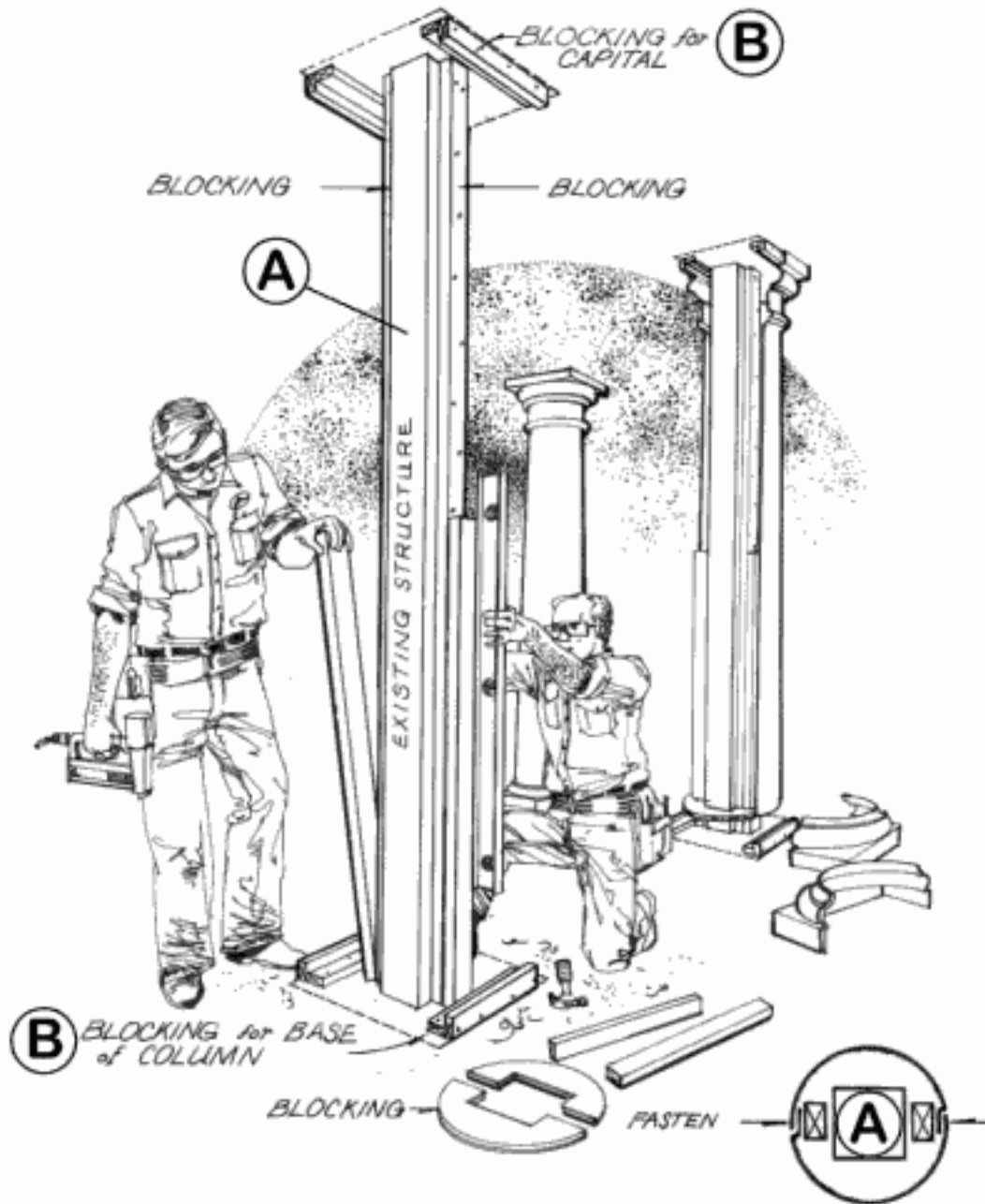

### INSTRUCTIONS

- (A)** Block out from existing (or new) vertical structure for attachment of both column halves at seams. Ensure blocking is plum and level.
- (B)** \* Blocking Cap & Base use instructions 2 & 3 from Column Installation Instructions.

(Always install column capital first and work your way down towards the base.)

# EDON fiberglass

## COLUMN COVER INSTRUCTIONS

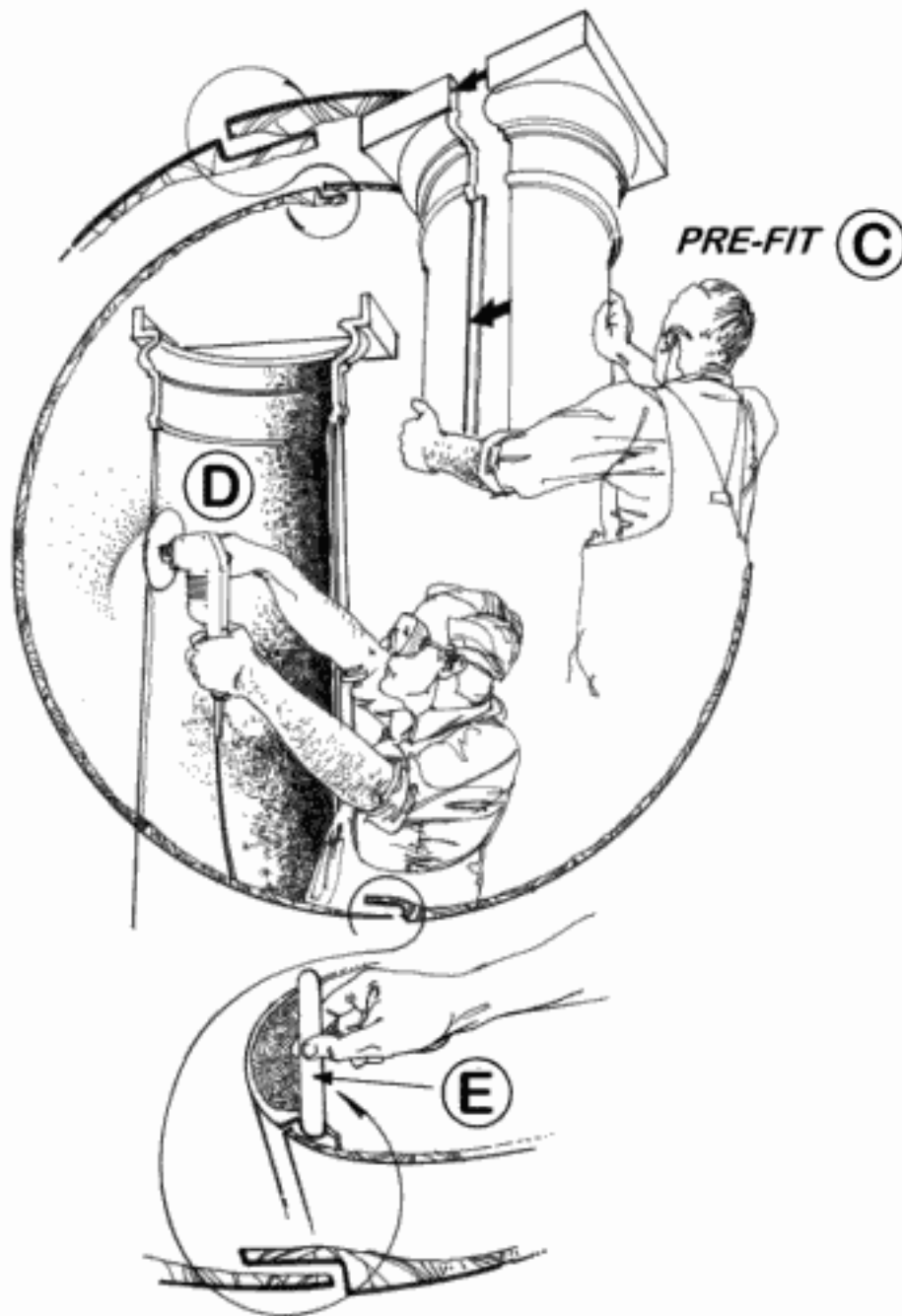

### INSTRUCTIONS

- (C)** Pre-fit both halves of the column blocking to insure proper fit.
- (D)** If material is too thick, unfinished side can be easily grinded or sanded down to properly fit over lap joint.
- (E)** If material appears to thin, prepare to shim so surface fit plumb.

# EDON fiberglass

## COLUMN COVER INSTRUCTIONS

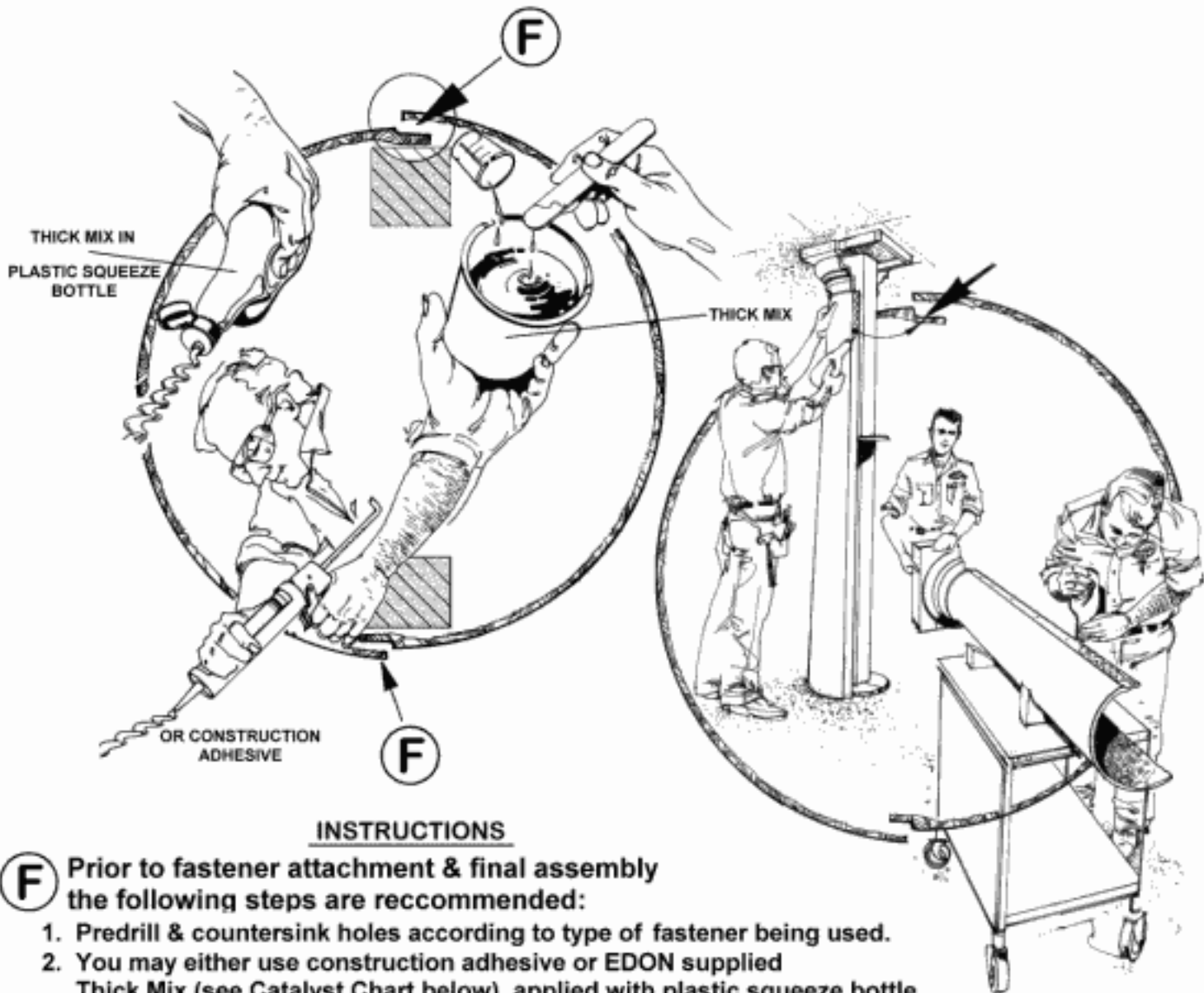

### INSTRUCTIONS

**F** Prior to fastener attachment & final assembly the following steps are recommended:

1. Predrill & countersink holes according to type of fastener being used.
2. You may either use construction adhesive or EDON supplied Thick Mix (see Catalyst Chart below), applied with plastic squeeze bottle
3. Start by attaching the capital first, using the proper screws, and work your way down the shaft to the base. The base halves will cover any uneven cuts, edges and shim material at the bottom of column (if necessary).

**4. *Mixing Catalyst Instructions:***

Add 7½ cc or ¼ oz. to each pint of thickmix. Stir thoroughly (you should have 20-30 minutes before cure time). If thickmix cures too fast, put less catalyst in the mix. If you wish to accelerate curing, add a small additional amount to the mix.

5. Apply thickmix or construction adhesive to seams of both installed and uninstalled halves.
6. Upon fastening both sections wipe off excess thickmix/adhesive.

# EDON fiberglass

## COLUMN COVER INSTRUCTIONS

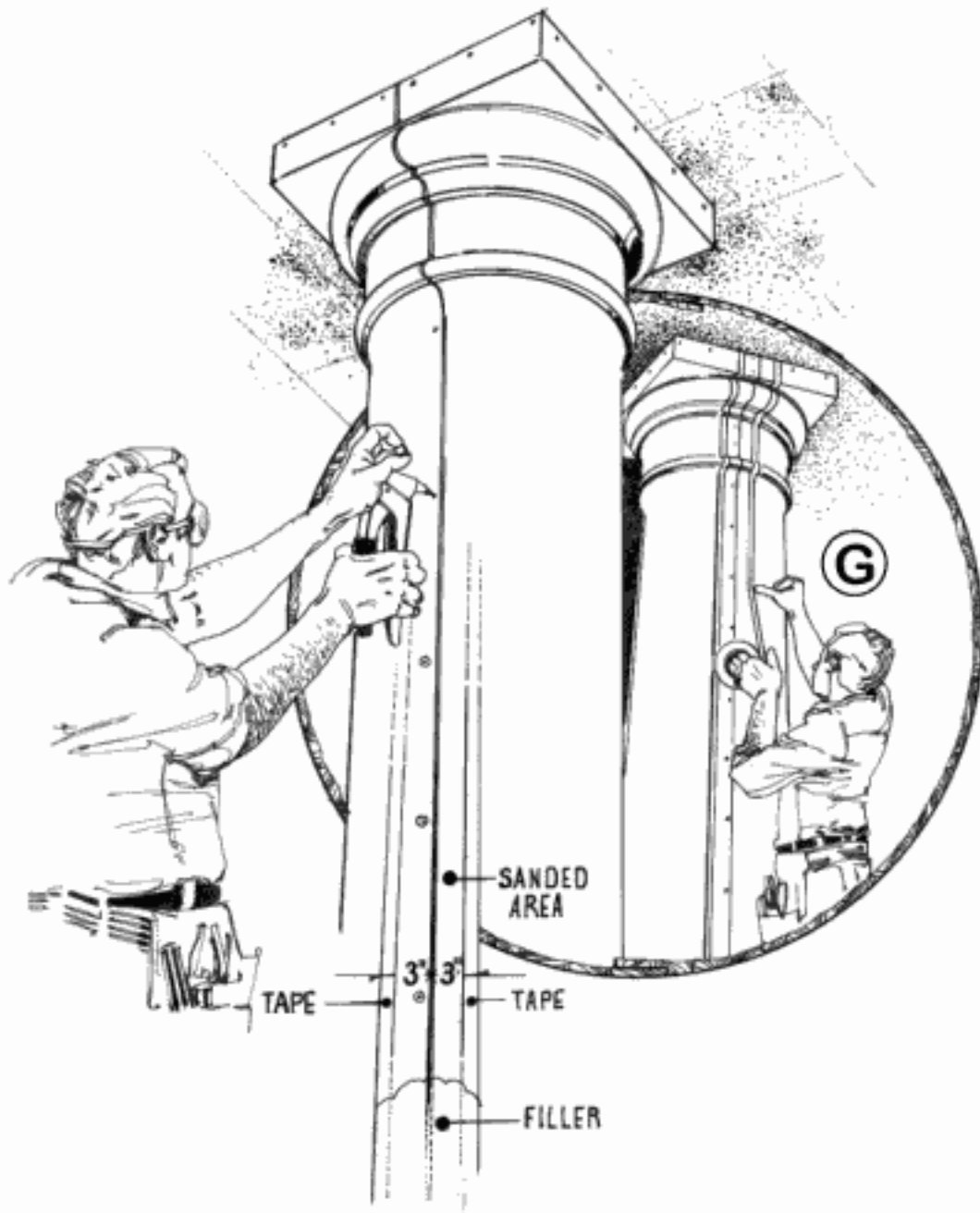

### INSTRUCTIONS

1. Quickly position remaining column half, starting at the capital (shim lap joints at this point, if necessary) then fasten. Clean off excess thickmix with acetone. Repeat the previous steps to install column base.
2. Sand the columns approximately two (2) inches on each side of the joint, using grade #200 sandpaper. Apply masking tape vertically on the columns two(2) inches on each side of the joint and apply a thin layer of polyester body filler over the joints and rivets.

# **EDON** fiberglass

## **COLUMN COVER INSTRUCTIONS**

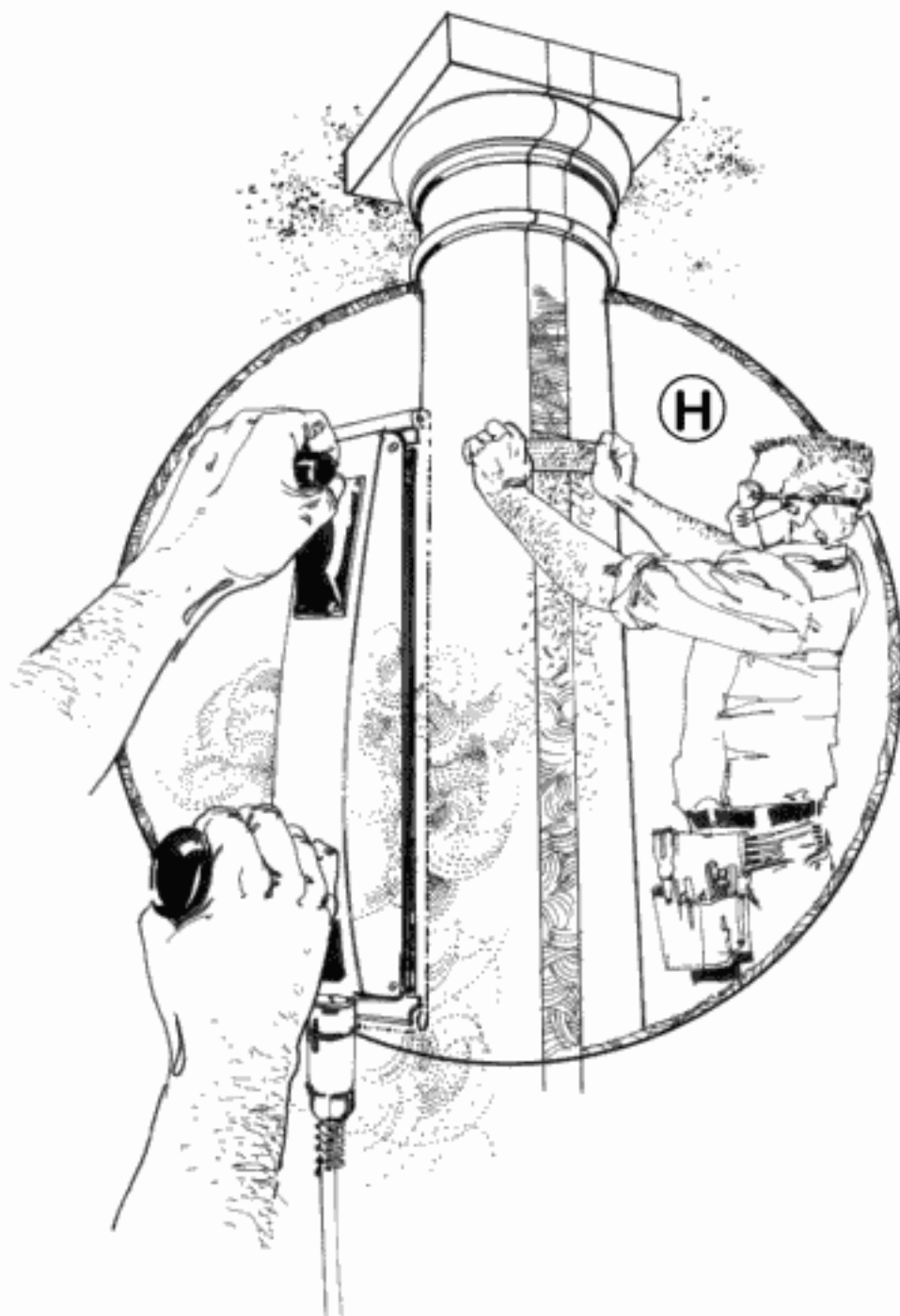

### INSTRUCTIONS

**Remove tape and feather body filler into the columns.**

# **EDON** fiberglass

## COLUMN COVER INSTRUCTIONS



### INSTRUCTIONS

Sand smooth and prime the body filler sections of the columns. You are now ready for the final finishing coat. Scuff entire column with scotchbrite pad to prepare for painting.

\* Gel-Coat finish must be sanded for primer/paint to adhere to column cover.



# EDON fiberglass

## COLUMN COVER INSTRUCTIONS

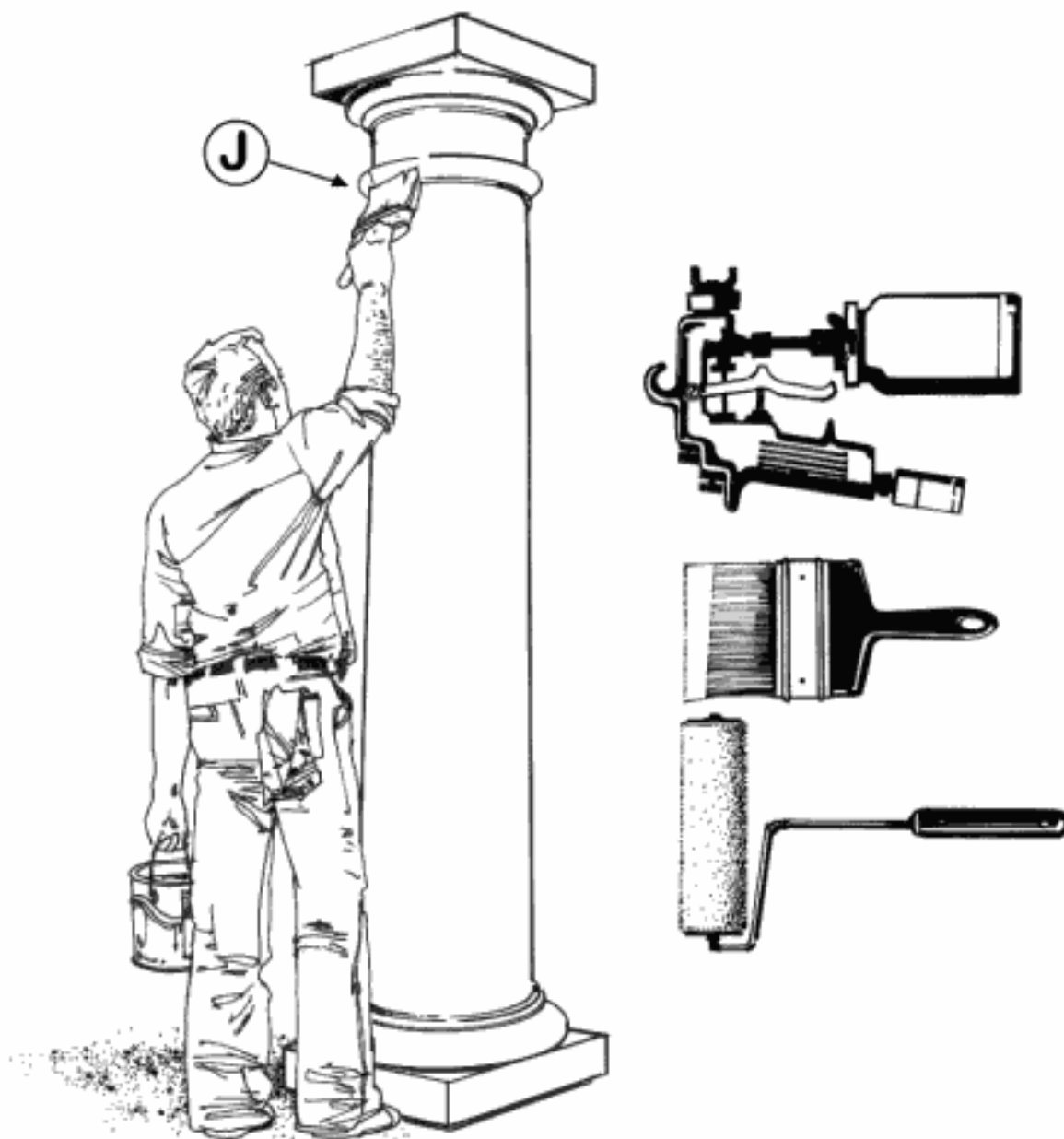

### INSTRUCTIONS

The following steps are recommended when preparing the FRP Columns for paint:

1. Wipe down the column covers with a wax/grease remover.
2. Lightly sand the column cover with sandpaper 200-400 grit or scotchbrite.
3. Wipe with clean cloth.
4. Prime column covers if you are using a water based paint. It is not necessary to prime other paints.
5. Make sure the areas that have patch & body work are primed prior to painting.
6. Paints recommended for column covers:

Oil Base, Exterior House Paint  
Urethane (1 or 2 Paint System)  
Acrylic Urethane (water soluble)